

CODE: SCB12-12 v.1.0/I
NAME: 12Ah/12V SCB battery

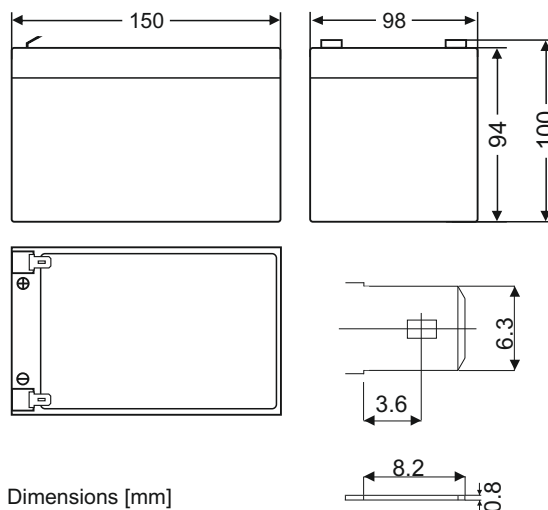

Dimensions [mm]
Tolerance: +/- 2mm;

APPLICATION:

SCB batteries are maintenance-free Valve Regulated Lead Acid Batteries with self-regulating one-sided safety valves and internal gas recombination.

The batteries are made in AGM (Absorbent Glass Mat) technology; the electrolyte is held in the glass mat. The technology used allows installing batteries in places with natural (gravity) ventilation and minimizes maintenance.

They are dedicated for devices requiring emergency power to a load when the input power source or mains power fails, such as:

- Security systems (CCTV, I&HAS, ACC)
- UPS
- Automation systems

TECHNICAL DATA

Nominal voltage:	12 V
Nominal capacity:	12Ah / C ₂₀ *
Projected lifespan:	3 + 5 years at 20°C
Internal resistance:	≈ 16 mΩ
The permissible operating temperature range:	
- during charging	0°C + 40°C
- during discharge	-15°C + 50°C
- during storage	-20°C + 40°C
The charging voltage at 25°C:	
Buffer operation	13,5 + 13,8 V (-18mV/°C)
Cyclic operation	14,4 + 14,9 V (-30mV/°C)
Charging current:	
Recommended	1,2 A
Maximum	3,6 A
Terminals:	see technical drawing above
The maximum discharge current (5s):	180 A (5 sec.)
Weight:	~ 3,3 kg
Dimensions:	W=150, H=100, D=98 [mm, +/-2]
Warranty:	1 year
Notes:	maintenance-free battery, made with AGM technology contains lead

*- the actual capacity at 20 h discharge

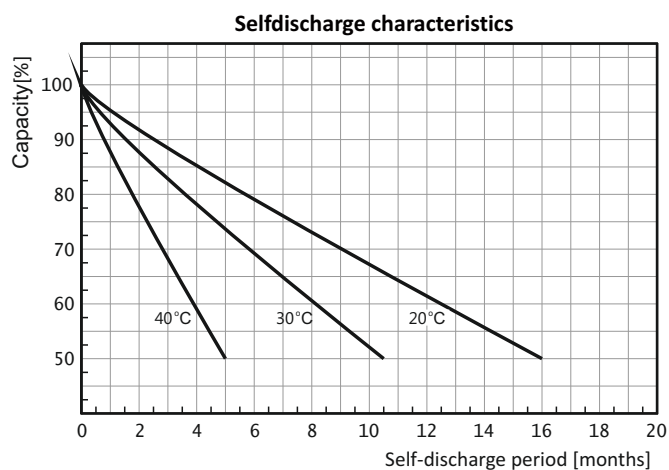
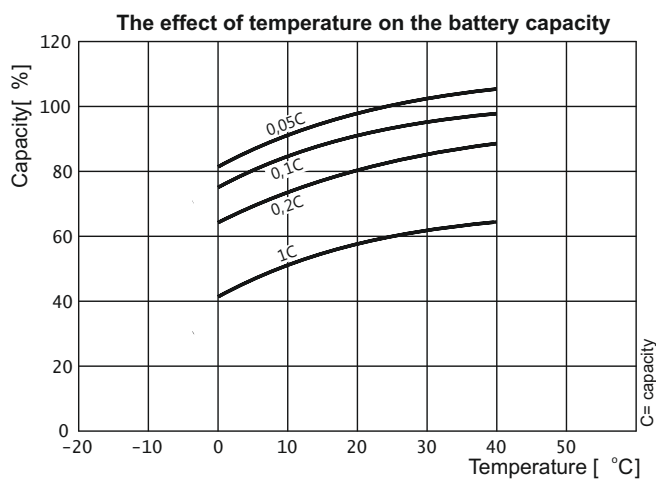
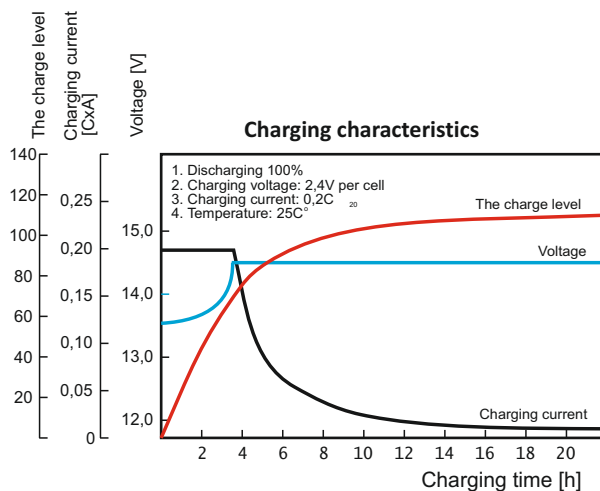
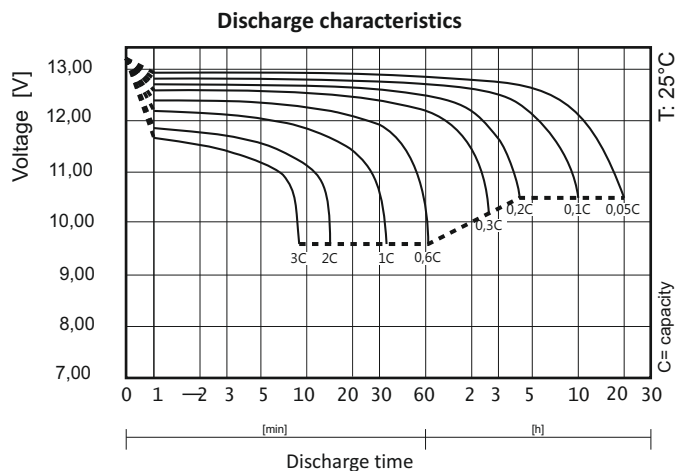

TRANSPORT INFORMATION:

The battery can be shipped by air, sea, or land. Classified as non-dangerous good according to: IATA/ICAO Special Provision A67, IMDG Special Provision 238, ADR (road), RID (rail), and 49 CFR Ch. 1 § 171-189.

